



GENUINE PARTS

INSTALLATION INSTRUCTIONS

DESCRIPTION:	Body Side Molding
APPLICATION:	NV200
PART NUMBER:	Body Side Molding (999G2 FZ00x)

KIT CONTENTS:

Item	Qty.	Part Description	Service Part Number
A	1	Body Side Molding (LH)	999G2 FZ001
B	1	Body Side Molding (RH)	999G2 FZ002
C	1	Installation Instruction Replacement Template	---



A



B



C

TOOLS REQUIRED:

- Clean, Lint-Free Wiping Cloth
- 90% plus alcohol solution
- Roller (optional)
- Scale
- Masking Tape

PRE-INSTALLATION WARNINGS, CAUTIONS, CRITICAL STEPS, and NOTES:

- Dealer installation recommended. Instructions may refer to Service Manual.

NOTE:

- Failure to clean mounting surface properly may cause tape to have poor adhesion to vehicle.
- If vehicle has been recently repainted, please allow vehicle paint to dry and age 24 hours before installing body side moldings.
- Install body side moldings when ambient temperature is above 15°C (60°F).
- Do not wash or expose vehicle to a wet environment for 24 hrs after installing moldings.
- Please use proper pressure of 103kPa (15lbs) to adhere body side molding to door.
- These installation instructions are for left side of vehicle; same procedure applies to right side.
- Alignment of all body side moldings must be on flat door surfaces. Moldings can not hang over door edges and no gaps allowed. Please follow instructions very carefully for alignment of molding to door edges.

INSTALLATION PROCEDURE:

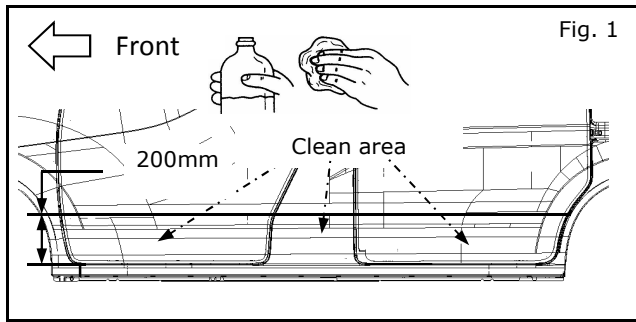

- 1) Clean driver's side vehicle area thoroughly with soap and water to remove any dirt or debris and allow to dry. (See Fig. 1)
- 2) Using a clean, lint-free cloth and 90% alcohol solution, clean area on doors where part will be installed. (See Fig. 1)

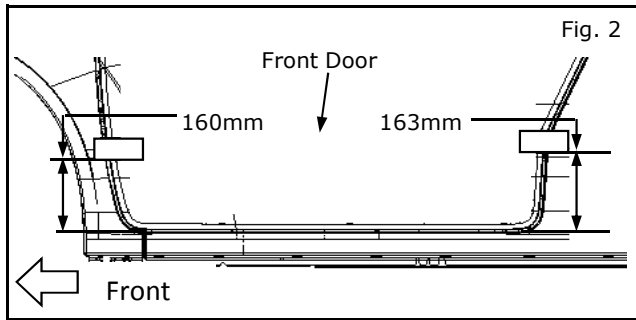

- 3) Place masking tape in 2 places as measured from the bottom of the front door as shown in Fig. 2.

Note: Keep tape parallel

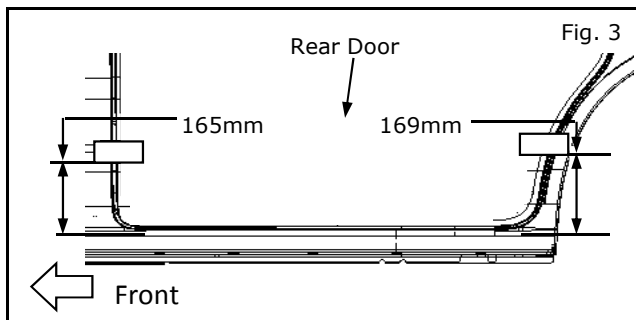

- 4) Place masking tape in 2 places as measured from the bottom of the rear door as shown in Fig. 3.

Note: Keep tape parallel

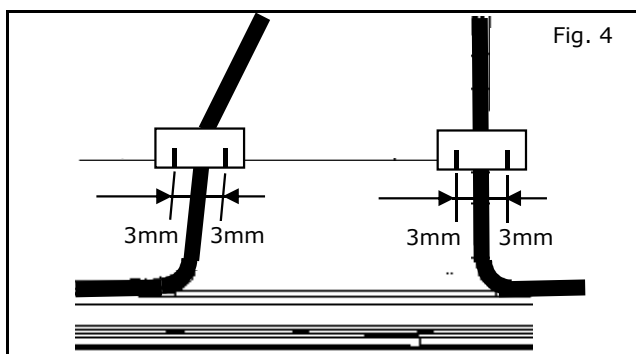

- 5) Measure 3mm from edge of door and body and mark on tape in 4 places as shown in Fig. 4.

Note: Keep tape parallel

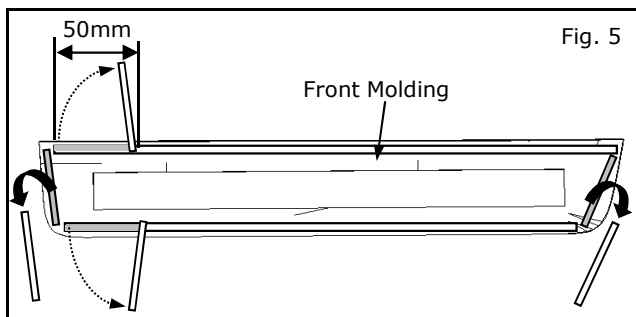

- 6) Remove vertical tape liners from front and rear edge of front molding and peel back horizontal liners 50mm as shown in Fig. 5.

INSTALLATION PROCEDURE:

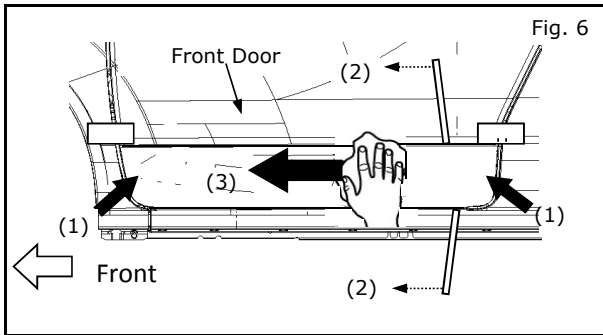

- 7) Align rear edge of front molding with 3mm mark on rear edge of front door. Align top of front molding with bottom edge of tape at front and rear of door.
Caution: Make sure all tape tabs are exposed. Press molding into place as shown in Fig. 6, step 1.

- 8) Peel top and bottom liner as shown in Fig. 6, step 2.

- 9) Apply 103kPa (15lbs) of pressure using a roller, or by hand with a clean rag from the rear, moving rear to front as shown in Fig. 6, step 3.

- 10) Remove vertical tape liners from front and rear edge of center molding and peel back horizontal liners 50mm as shown in Fig. 7.

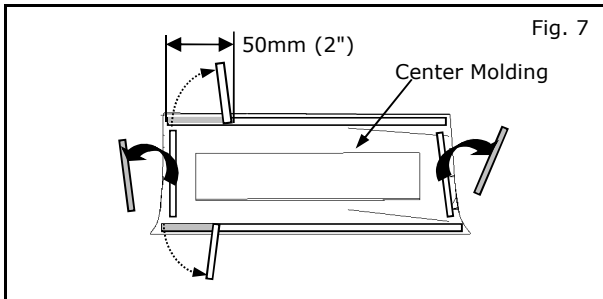

- 11) Align top edge of center molding with bottom edge of tape and 3mm marks on tape. Press molding into place as shown in Fig. 8, step 1.

- 12) Peel top and bottom liner as shown in Fig. 8, step 2.

- 13) Apply 103kPa (15lbs) of pressure using a roller, or by hand with a clean rag from the rear, moving rear to front as shown in Fig. 8, step 3.

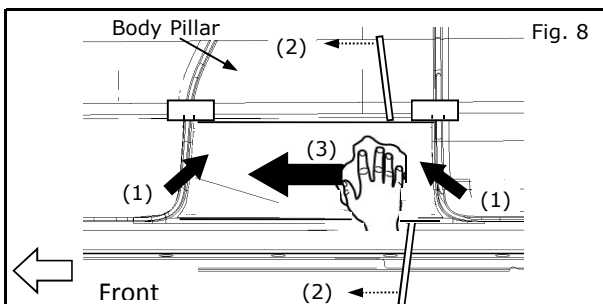

- 14) Remove vertical tape liners from front and rear edge of rear molding and peel back horizontal liners 50mm as shown in Fig. 9.

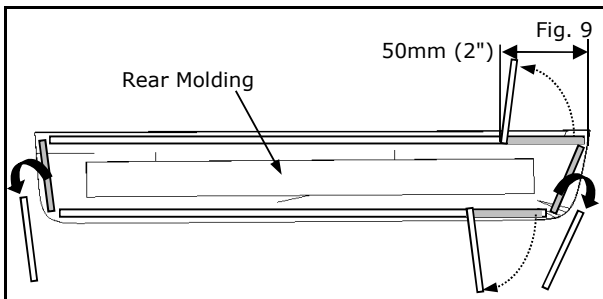

- 15) Align front edge of rear molding with 3mm mark on front edge of rear door. Align top of rear molding with bottom edge of tape at front and rear of door. Press molding into place as shown in Fig. 10, step 1.

- 16) Peel top and bottom liner as shown in Fig. 10, step 2.

- 17) Apply 103kPa (15lbs) of pressure using a roller, or by hand with a clean rag from the rear, moving front to rear as shown in Fig. 10, step 3.

- 18) Remove masking tape.

- 19) Repeat process for passenger side of vehicle.

